

VERSA-BELL II™

50lb Adjustable Dumbbell

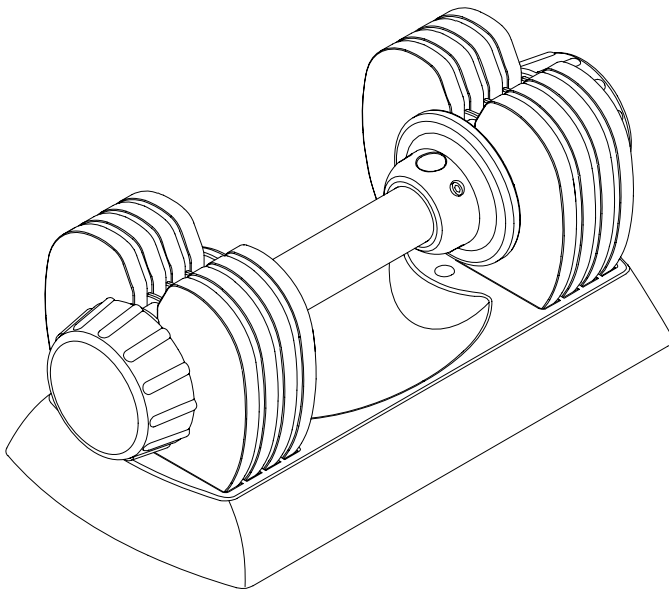

Owner's Manual

Safety Instructions
Customer Service
Operation
Warranty

SAFETY INSTRUCTIONS

WARNING: To reduce the risk of serious injury, read the following Safety Instructions before using the VERSA-BELL II.

1. Read this Owner's Manual and follow it carefully before using the **VERSA-BELL II**.
2. Keep children away from the **VERSA-BELL II**. Do not allow children to use or play around the **VERSA-BELL II**. Keep children and pets away from the **VERSA-BELL II** when it is in use.
3. Make sure the **VERSA-BELL II** is resting in a horizontal position in the Weight Tray.
4. Inspect the **VERSA-BELL II** for damaged or loose components prior to use.
5. Tighten/replace any loose or worn components prior to using the **VERSA-BELL II**.
6. Before exercising, Check both Select Knobs to verify the Weight Plates are secured properly. Falling Weights can result in severe injury.

CAUTION: Never adjust the Select Knobs when the **VERSA-BELL II** is removed from the Weight Tray.

7. Consult a physician prior to commencing an exercise program. If, at any time during exercise, you feel faint, dizzy, or experience pain, stop and consult your physician.
8. Always choose the workout which best fits your physical strength and flexibility level. Know your limits and train within them. Always use common sense when exercising.
9. Do not wear loose or dangling clothing while using the **VERSA-BELL II**.
10. The **VERSA-BELL II** is for consumer use only. It is not for use in public or semipublic facilities.

This Product is Produced Exclusively by



2040 N. Alliance, Springfield, MO 65803
Customer Service Number
1 (800) 375-7520
parts@staminaproducts.com
www.staminaproducts.com

When calling for parts or service, please specify the following number:

05-2150

Part No. and Description	Qty
1 Weight Tray	1
2 Weight Plate (5 lbs)	8
3 Handle	1
4 Hand Grip	1
5 Support Guide	2
6 Left Slider	1
7 Right Slider	1
8 Threaded Bar	2

Part No. and Description	Qty
9 Securing Block	2
10 Select Knob	2
11 Spring	2
12 Steel Ball	2
13 Bolt, Socket Head(M6x1x7mm)	8
14 Bolt, Socket Head(M6x1x20mm)	2
15 Bolt, Socket Head(M6x1x35mm)	4
16 Decal	2
17 Manual (not pictured)	1

OPERATIONAL INSTRUCTIONS

VERSA-BELL II has a internal slider system that allows the user to adjust the weights on both sides of the bar. Follow the following process to adjust and work out with your **VERSA-BELL II** :

1. While in the Weight Tray, turn the **SELECT KNOBS(10)** to adjust, one turn for one Weight Plate. To increase the weight, turn the **SELECT KNOBS(10)** clockwise. To decrease the weight, turn the **SELECT KNOBS(10)** counterclockwise. The Weight Number Windows at each end of the hand grip display the amount of weight selected on each end of the **VERSA-BELL II**.
2. Lift the **VERSA-BELL II** approximately 6 inches from the Weight Tray and check the Weight Plates.
CAUTION: Never adjust the SELECT KNOBS(10) when the VERSA-BELL II is removed from the Weight Tray.
3. Start to work out if the Weight Plates are secure.

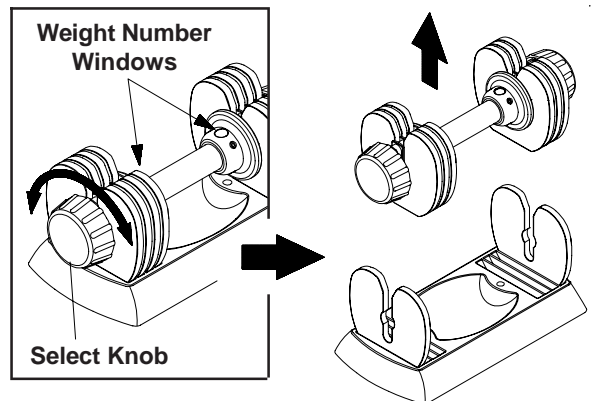

We recommend that you keep the **VERSA-BELL II** balanced as closely as possible. For example, if three weights are used, use two on one side and one on the other side. The illustrations below show the proper setup for 10, 20, 30, 40, and 50 pounds.

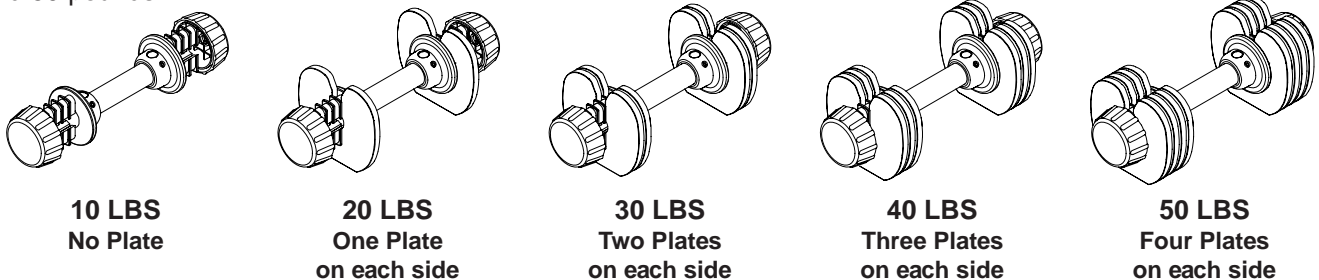

LIMITED WARRANTY

This product is warranted to be free from defects in material and workmanship and to be in perfect working order at the time of purchase. This warranty applies to personal, family or household use. This warranty does not apply to use in athletic clubs, health clubs, spas, gymnasiums, exercise facilities, and other public or semipublic facilities.

If the product should, for any reason, become defective within 90 days of purchase, the manufacturer will replace the product once it is returned to the manufacturer. This warranty does not apply to any damage caused by accident, return transit, alteration, abuse, or misuse. There are no other warranties other than those expressly set forth herein.

Products shipped to the manufacturer must be in the original shipping carton with freight prepaid. All expenses for repairing or replacing the product, including the cost of shipping it back to the original purchaser, will be covered by the manufacturer. This warranty gives you specific legal rights, and you may have other rights which vary from state to state.